

# Turbocharger Overview

## Overview of A Standard Turbocharger Unit

Illustrations Depict Basic Components And Air Flow

- Compressor Housing
- Bearing/Oil Housing
- Turbine Housing

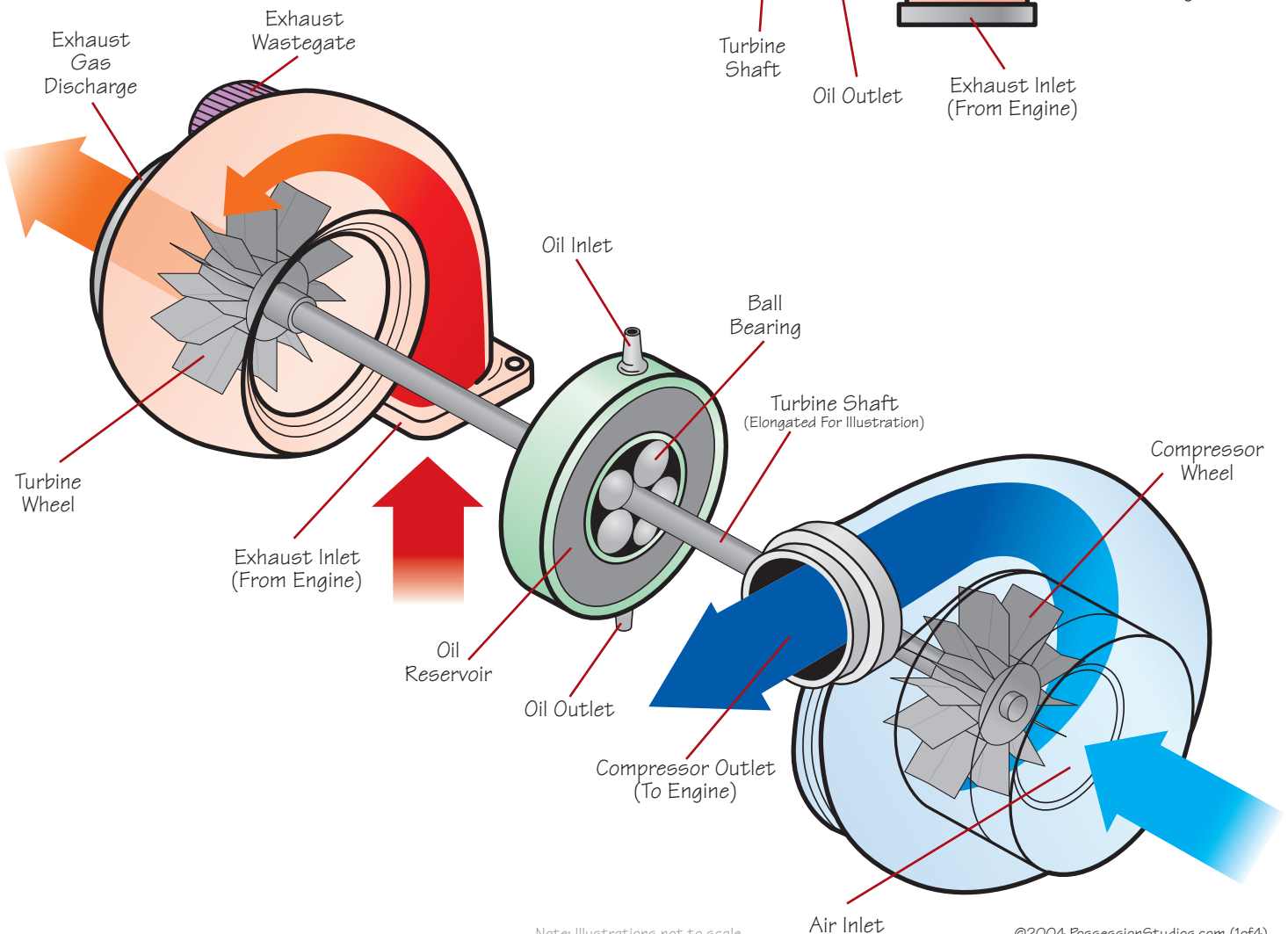
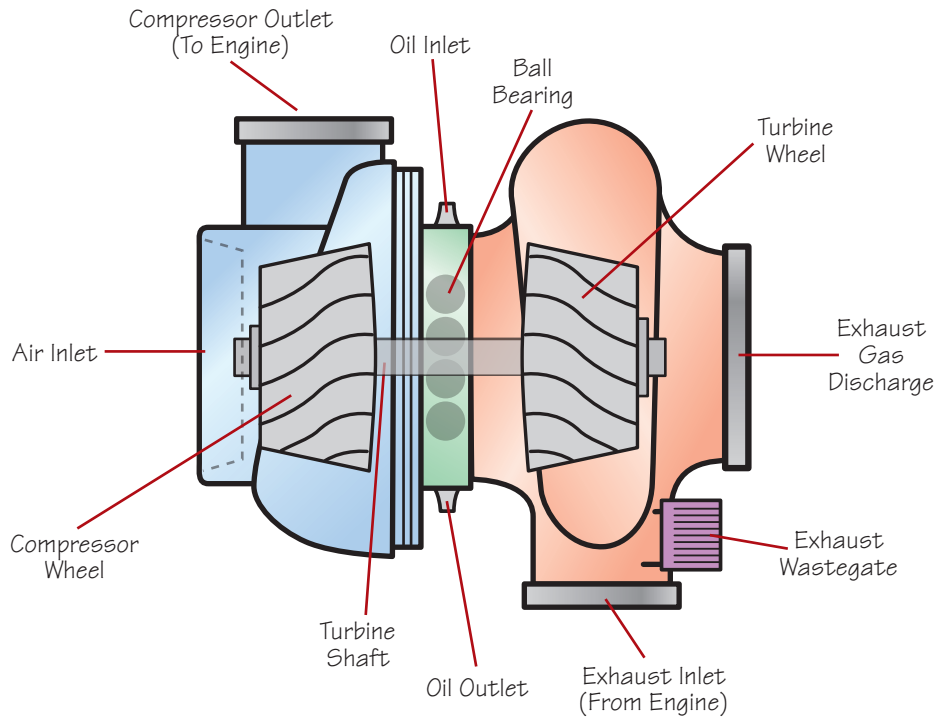

Note: Illustrations not to scale.

©2004 PossessionStudios.com (1of4)

# Turbocharger Plumbing

Overview of Basic Turbocharger Plumbing Layouts  
Illustrations Depict Plumbing Overview And Optional Equipment

## Basic Plumbing

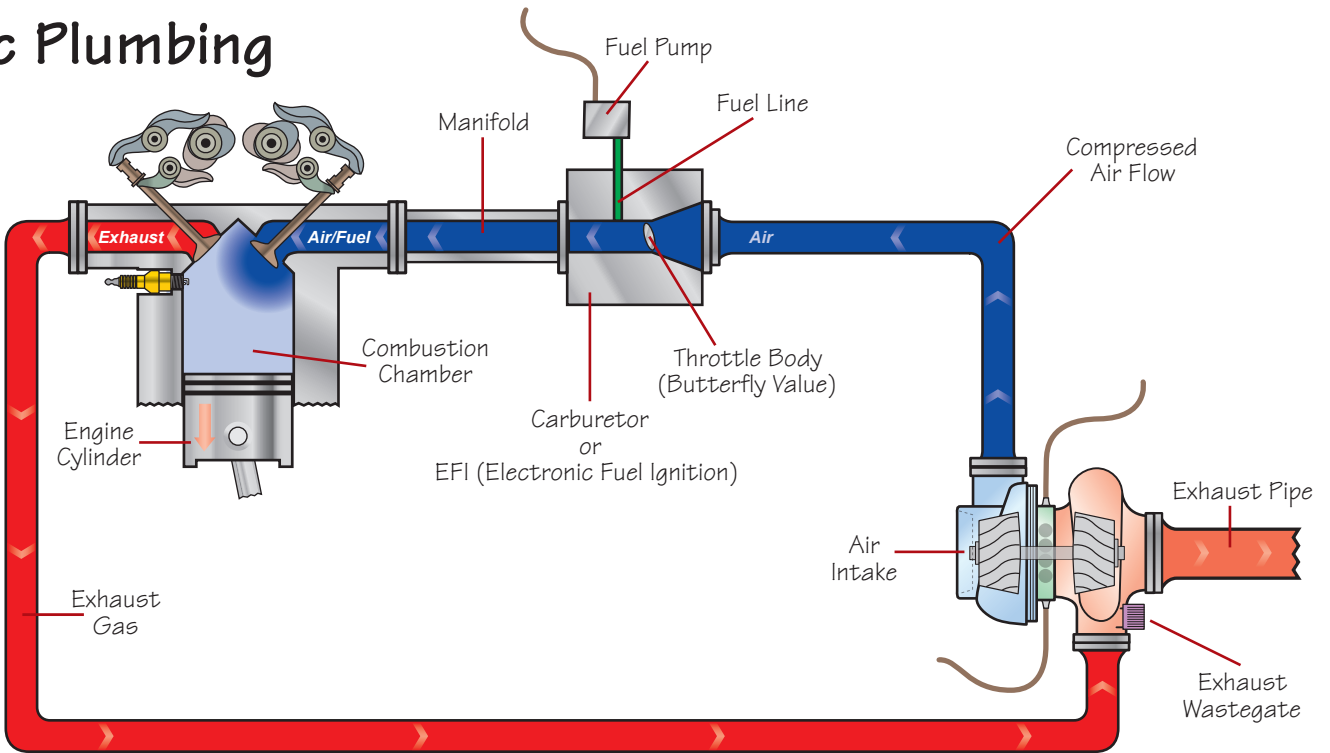

## Plumbing With Options

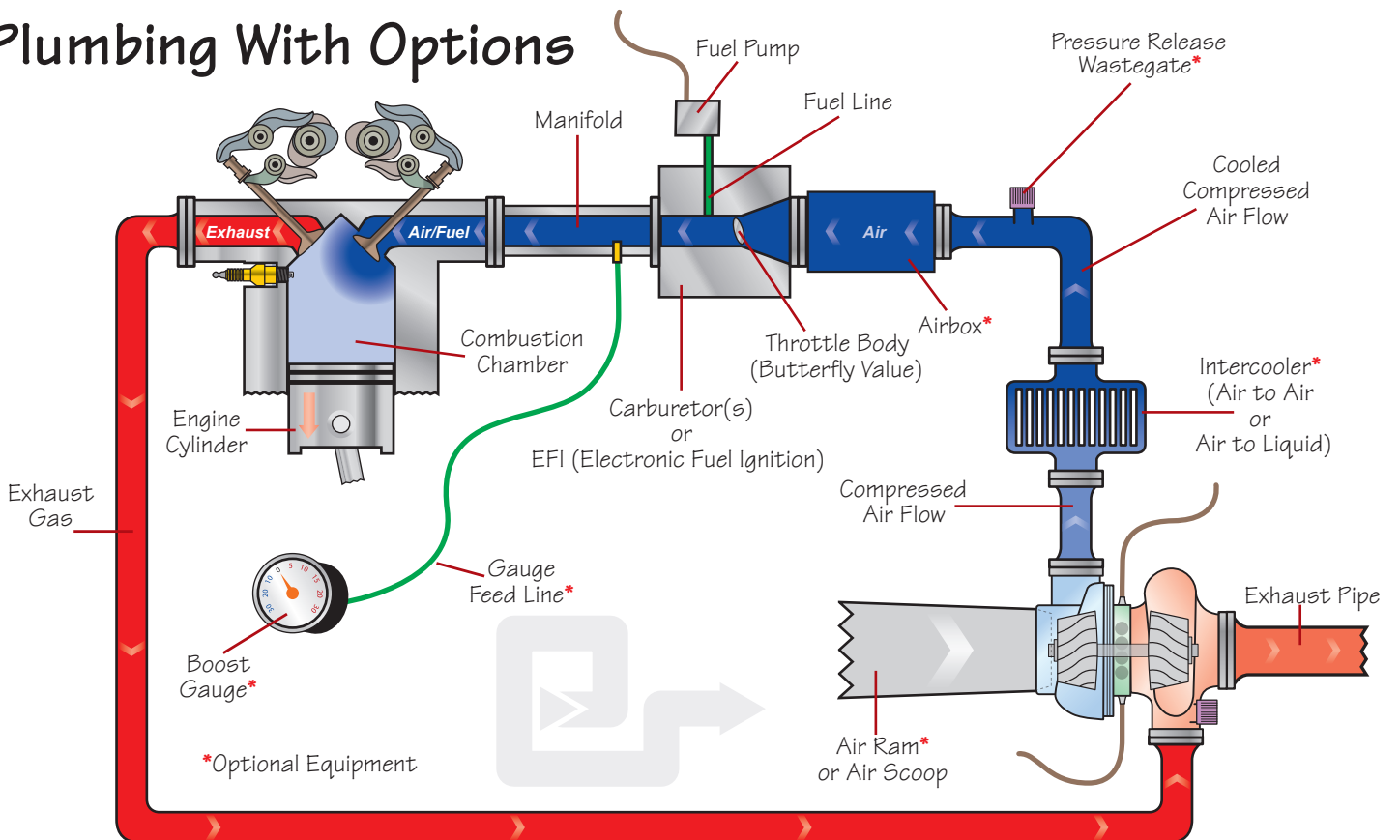

# Plumbing Samples

Samples of Basic Turbocharger Plumbing Layouts  
Illustrations Depict Plumbing For Ducati V-Twin (Turbo Monster)

## Ducati V-Twin (Standard)

Right Side View

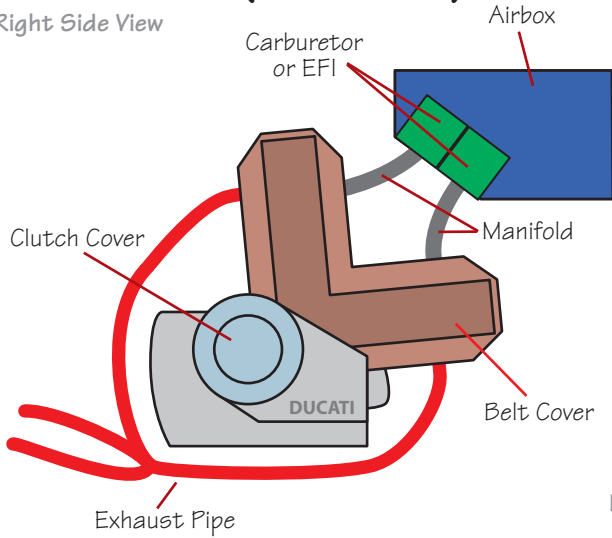

Left Side View

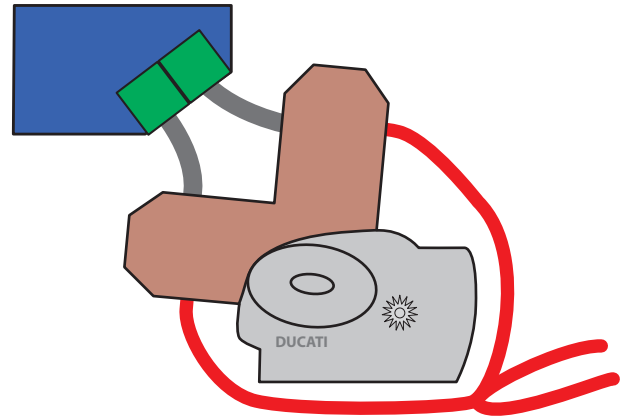

Bottom View

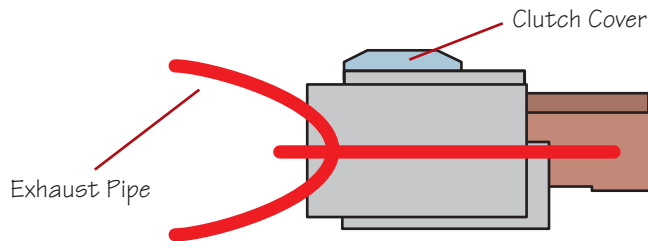

## Ducati V-Twin (Turbo)

Right Side View

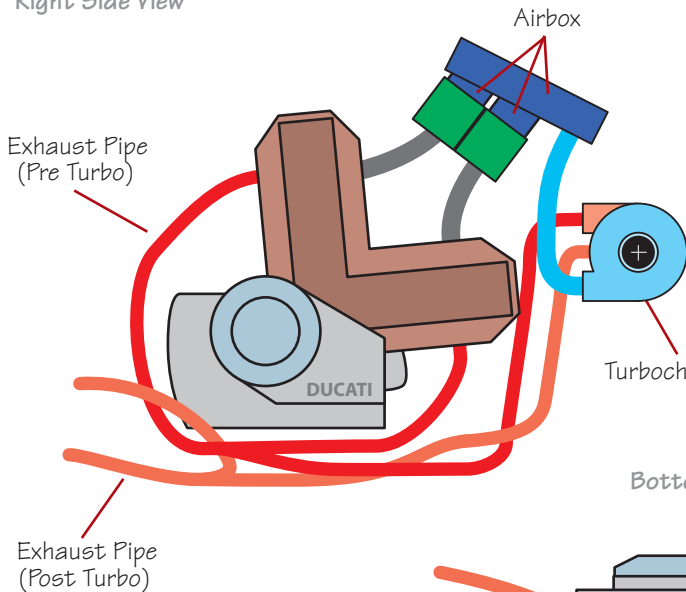

Left Side View

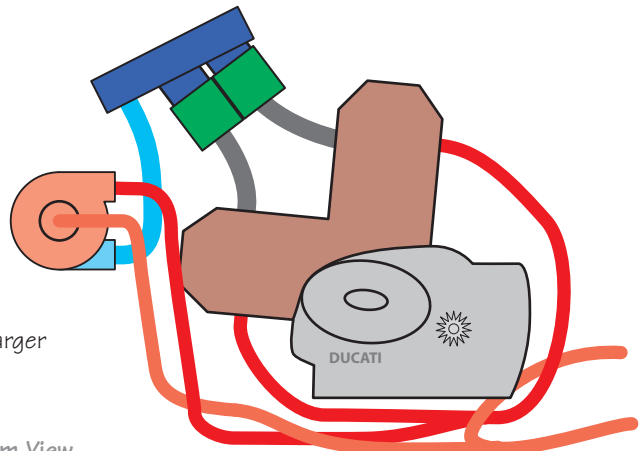

Bottom View

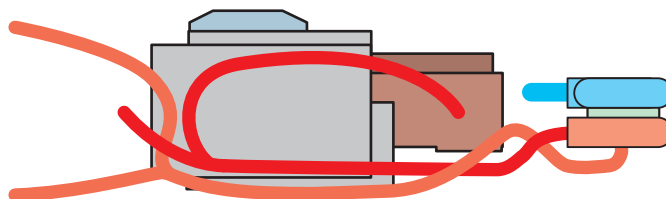

Note: Illustrations not to scale.

©2004 PossessionStudios.com (3of4)

# Plumbing Samples

Samples of Basic Turbocharger Plumbing Layouts  
Illustrations Depict Plumbing For Inline 4's & V8 Engines

### Inline 4 Engine (Standard/MX5)

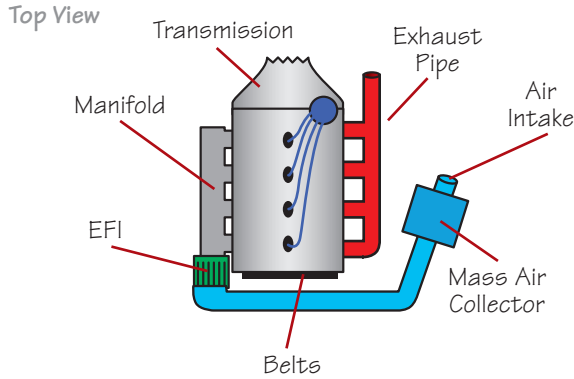

### Inline 4 Engine (Turbo/MX5)

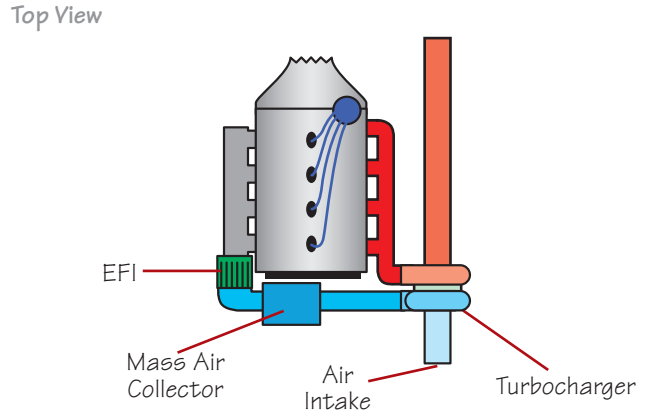

### Inline 4 Engine (Standard/Civic)

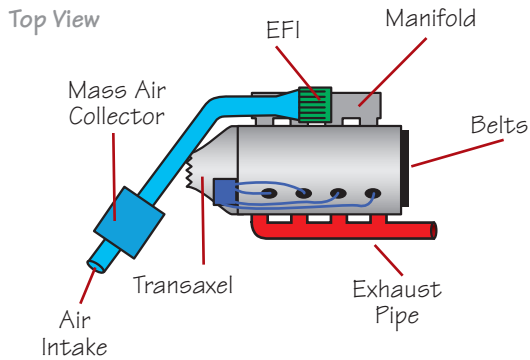

### Inline 4 Engine (Turbo/Civic)

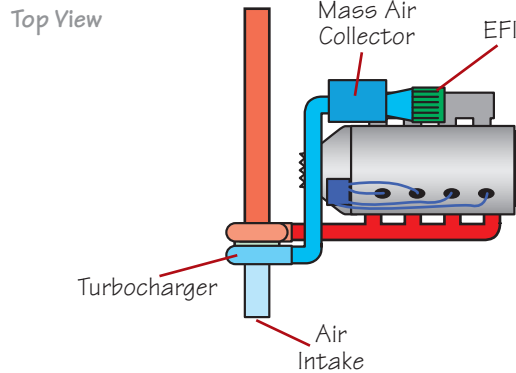

### V8 Engine (Standard/Chevelle)

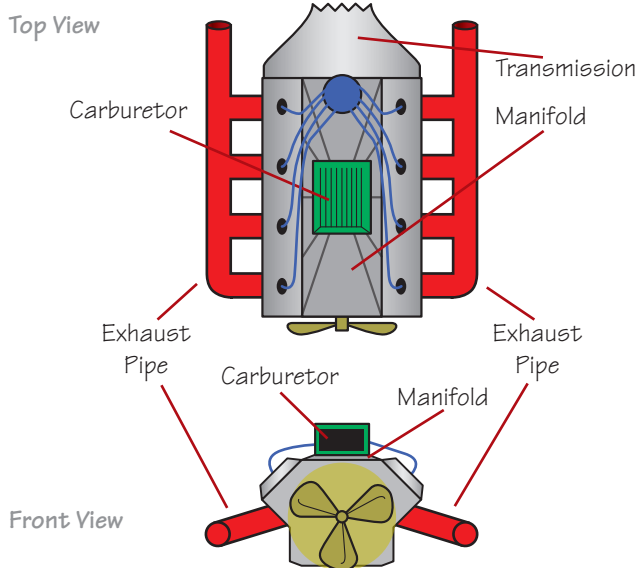

### V8 Engine (Dual Turbo/Chevelle)

